

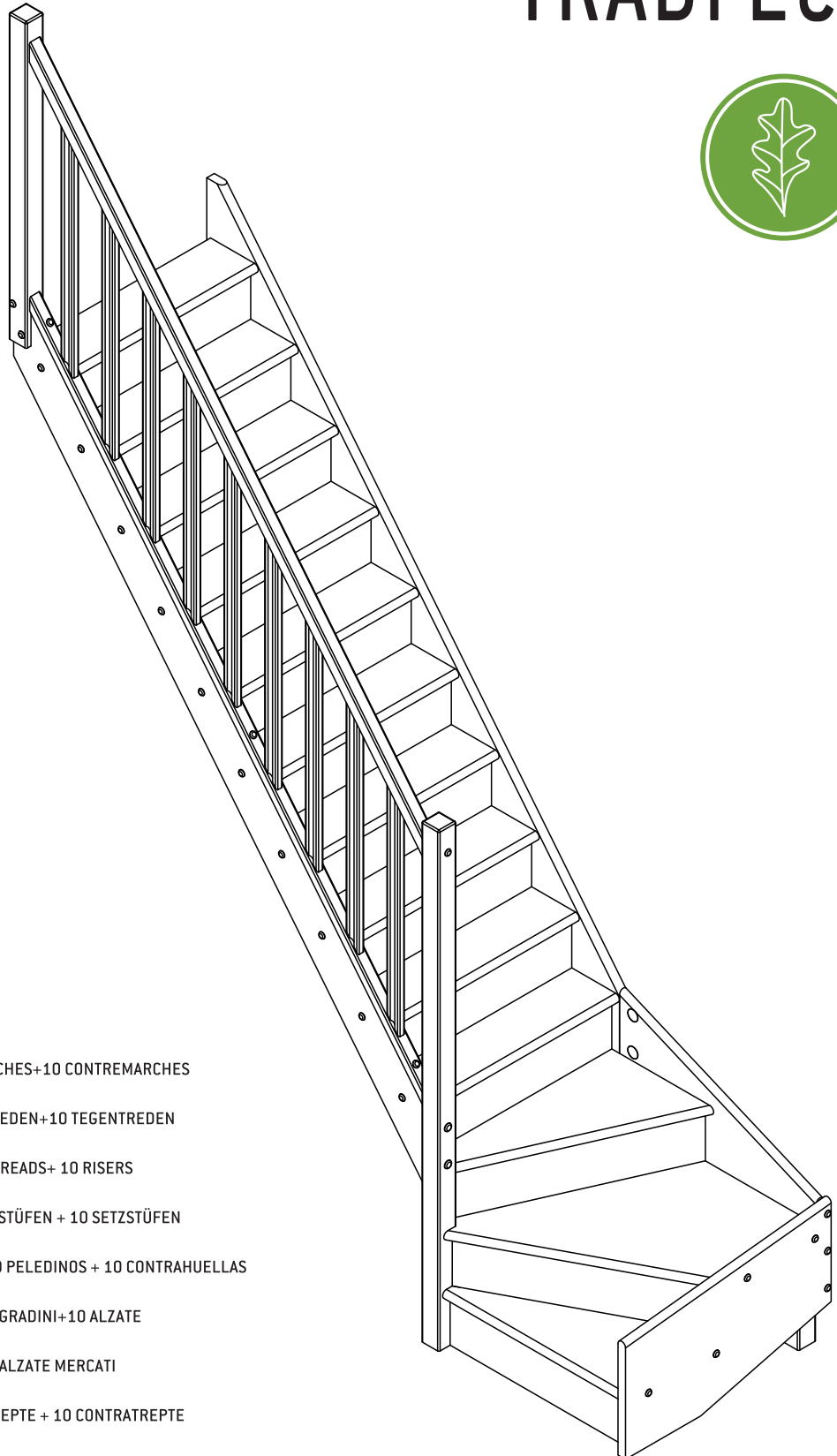

TRADI ECO

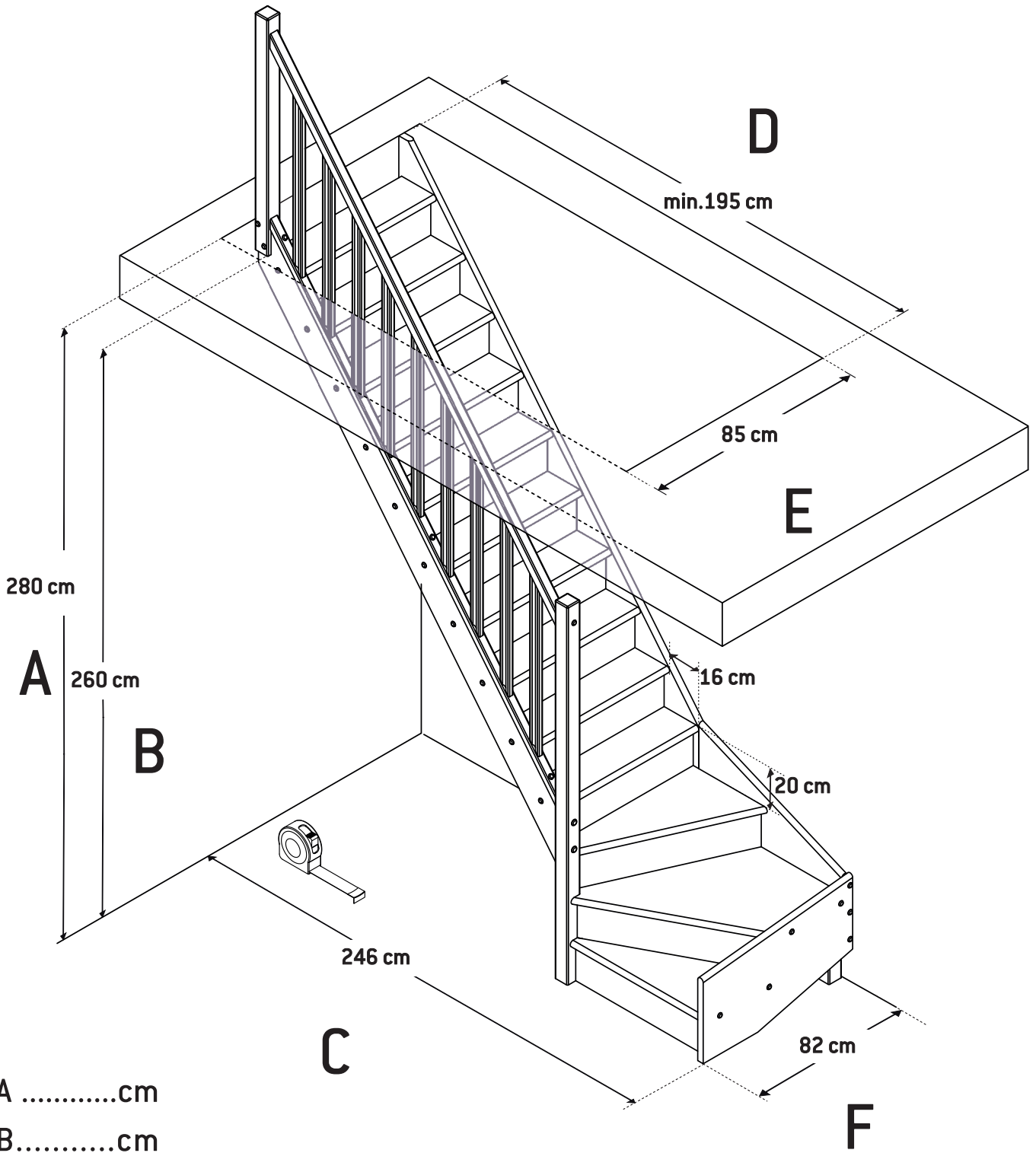

- Ⓡ FR TRADI ECO QT + 2 LIMONS + RAMPE +10 MARCHES+10 CONTREMARCHES
- Ⓡ NL TRADI ECO QT + 2 WANGEN + LEUNING+10 TREDEN+10 TEGENTREDEN
- Ⓡ GB TRADI ECO QT + 2 STRINGS + BANISTER + 10 TREADS+ 10 RISERS
- Ⓡ DE TRADI ECO QT + 2 WANGEN +GELANDER + 10 STÜFEN + 10 SETZSTÜFEN
- Ⓡ ES TRADI ECO QT + 2 ZANCAS + BARANDILLA + 10 PELEDINOS + 10 CONTRAHUELLAS
- Ⓡ PT TRADI ECO QT + 2 FIANCHI + RINGHIERA + 10 GRADINI+10 ALZATE
- Ⓡ IT TRADI ECO QT + 2 LIMONS + RAMPA +10 + 10 ALZATE MERCATI
- Ⓡ RO TRADI ECO QT + 2 LATERALE + RAMPA +10 TREPTE + 10 CONTRATREPTE



- Acm
- B.....cm
- Ccm
- Dcm
- Ecm
- Fcm



01 30x190 2816 x1 	02 30x190x2816 x1 	03 30x190x762 x10 	04 70x70x1796 x1 	05 70x70x1125 x1 	06 25x50x874.4 x9 	07 30x42x2580 x1 	08 16x26x2580 x1 	09 42x45x2580 x1 	
10 30x351x784 x1 	11 30x400x820 x1 	12 30x400x740 x1 	13 30x768x781 x1 	14 30x415x736 x1 	15 70x70x370 x1 	16 70x70x570 x1 	17 18x209x760 x10 	18 18x209x828 x1 	
19 18x209x828 x1 	20 18x177x735 x1 	21 45x25x242 x2 11.24 cm 	22 Ø12x11 x43 	23 Ø20x11 x2 	24 Ø40x5 x4 	25 Ø4x35 x3 	26 Ø4x40 x91 	27 Ø5x50 x24 	
28 Ø5x60 x21 	29 34x16 x2 	30 M8x80 x2 	31 M8x70 x2 	32 M8 x2 	 				

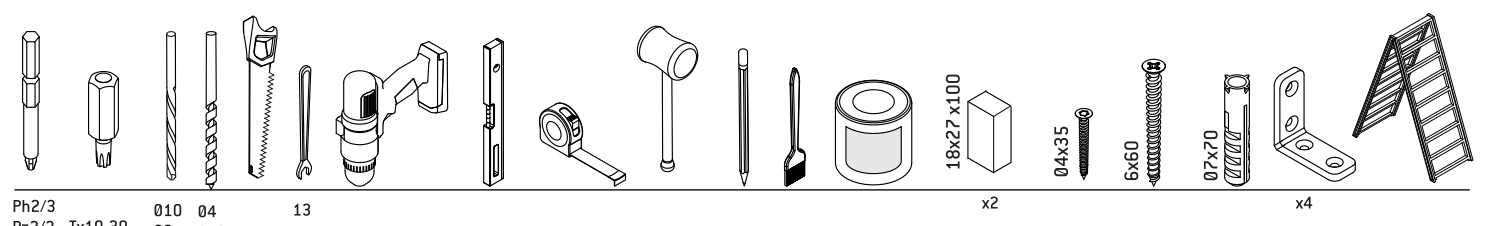



1

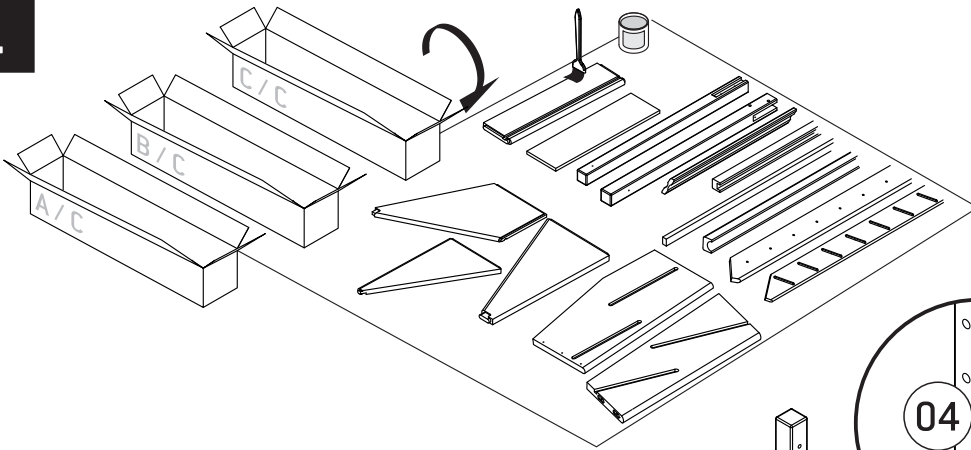

2

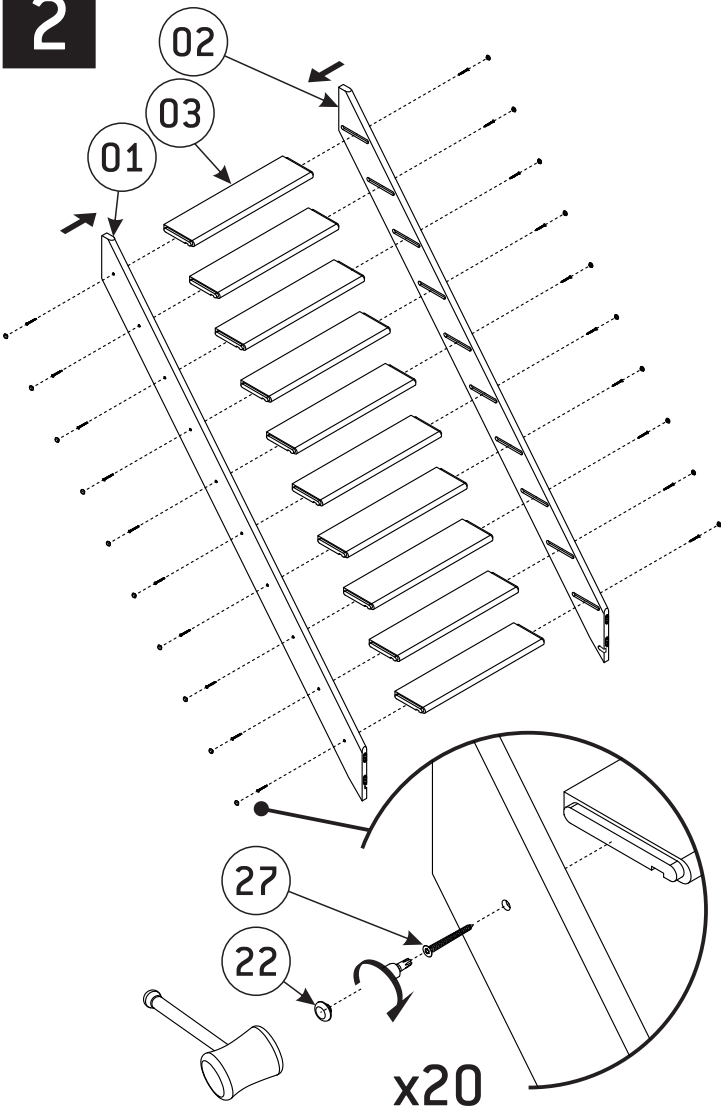

3

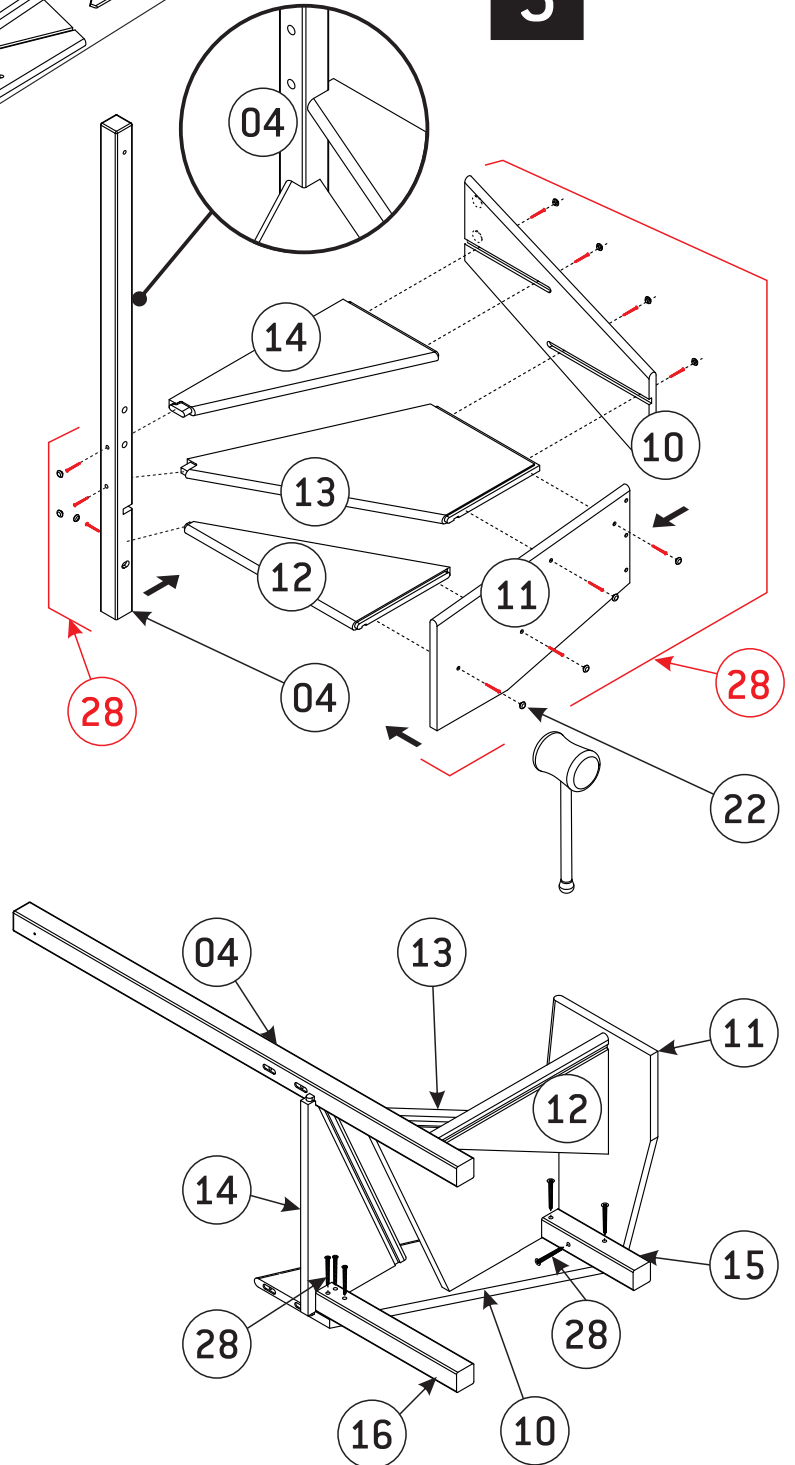



4

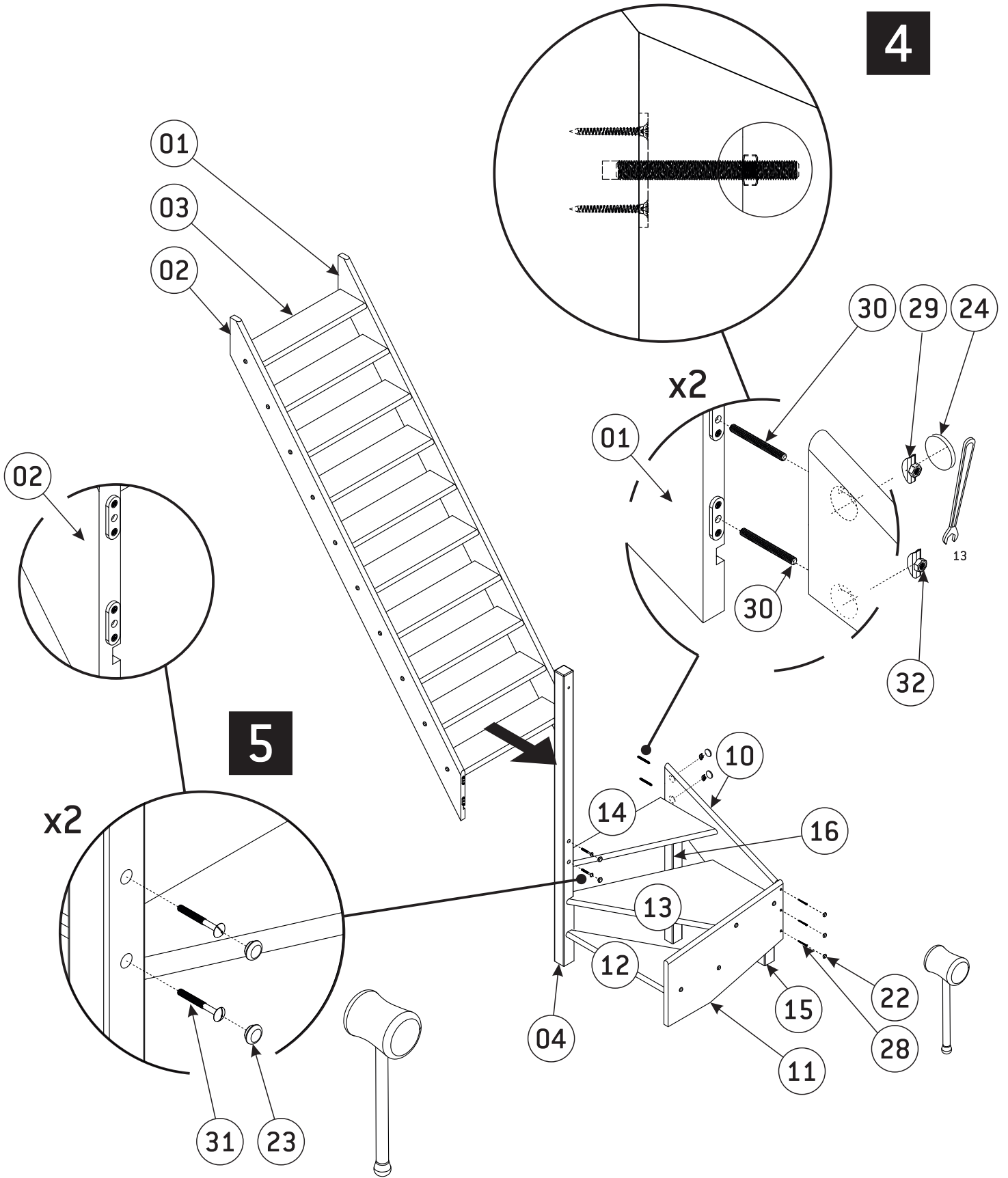

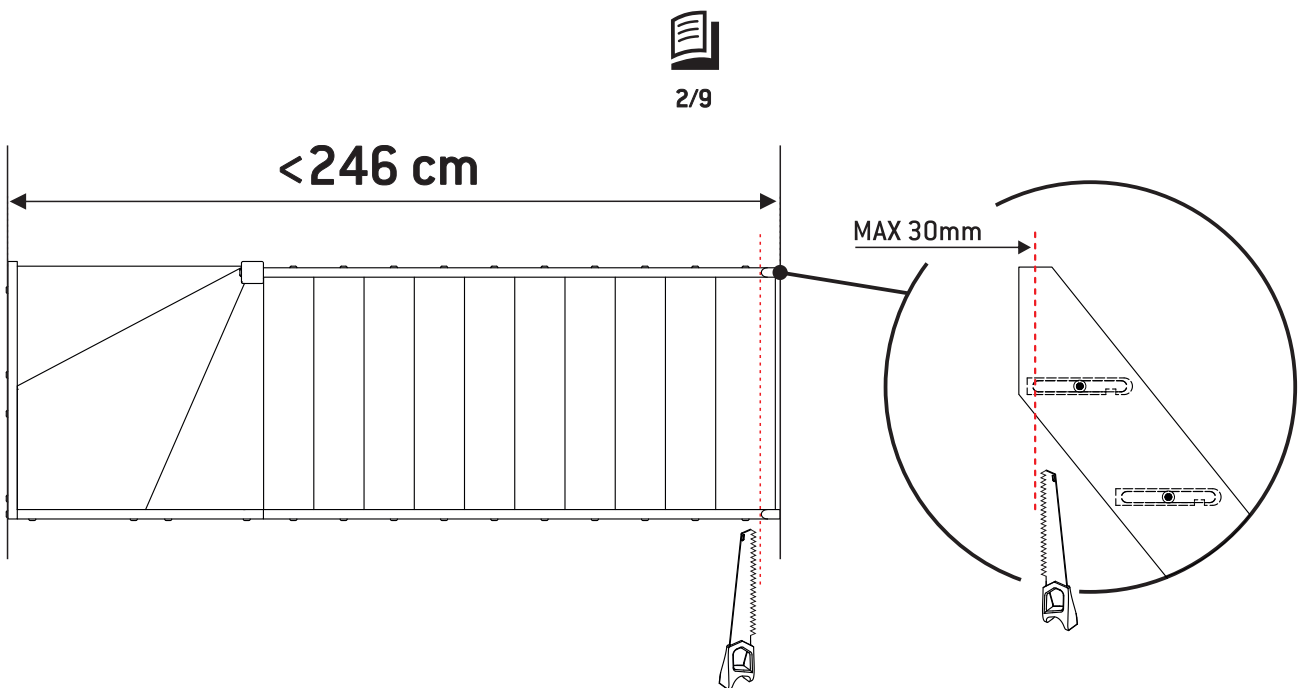
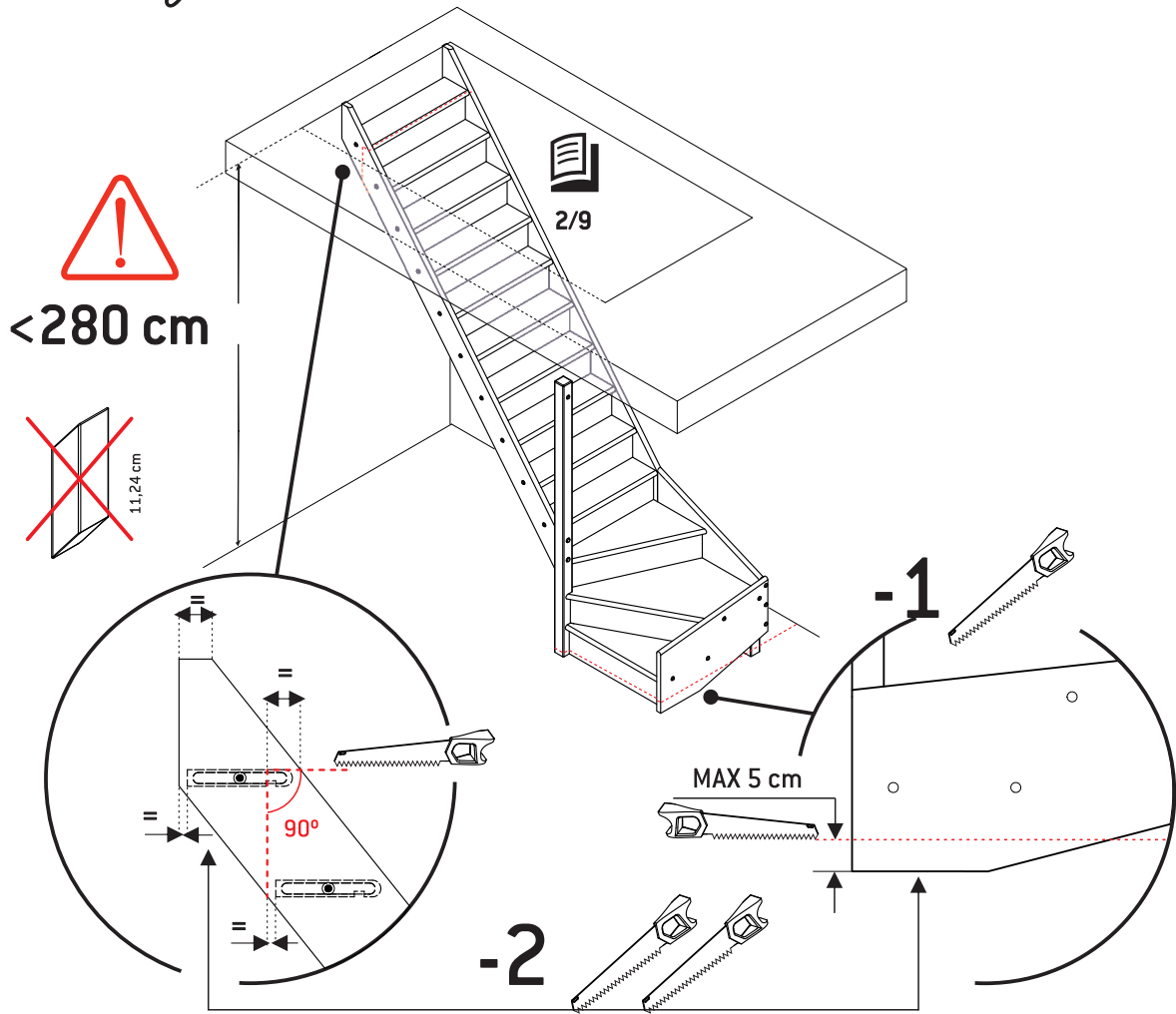



6

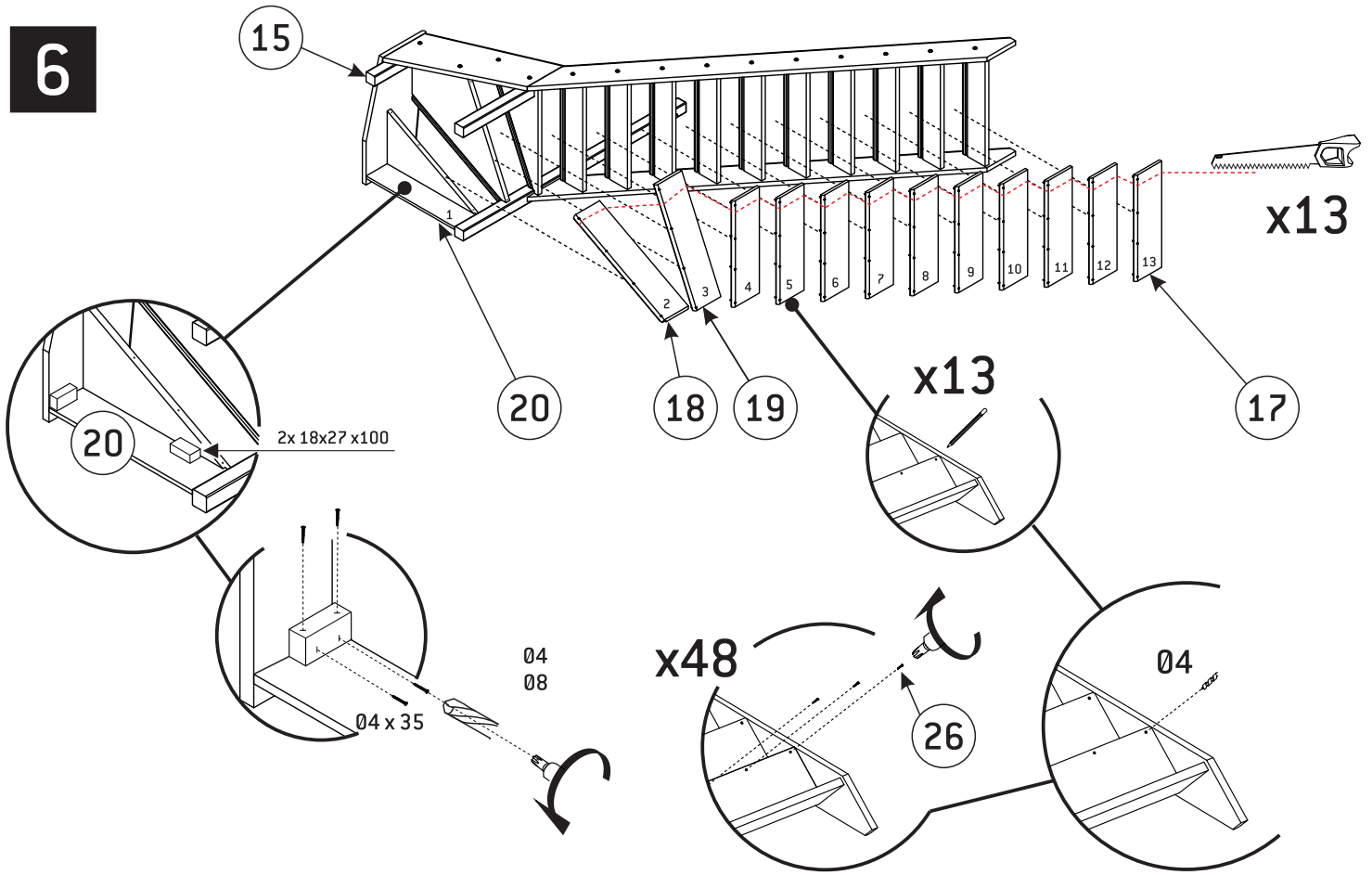

7

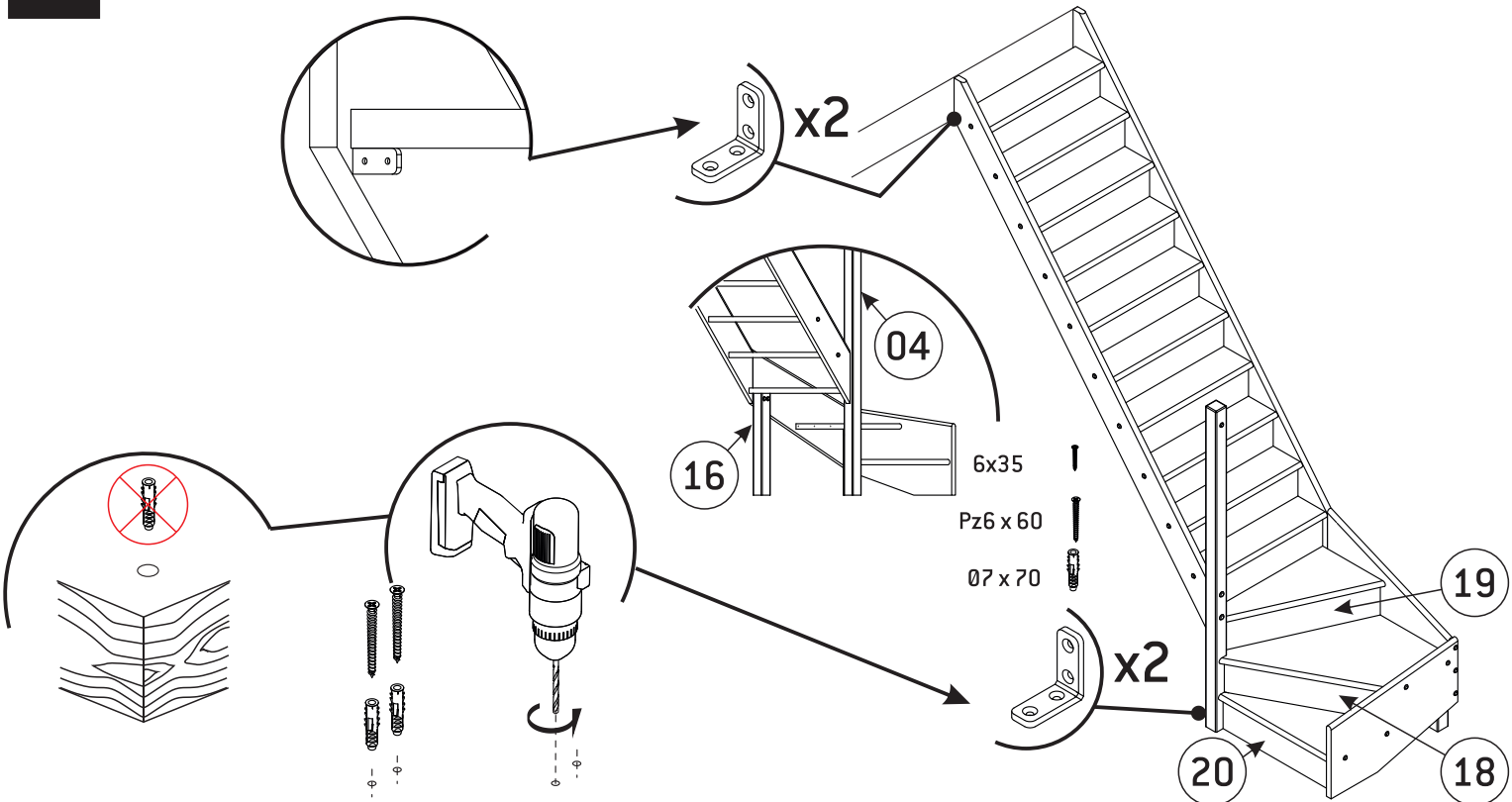



8

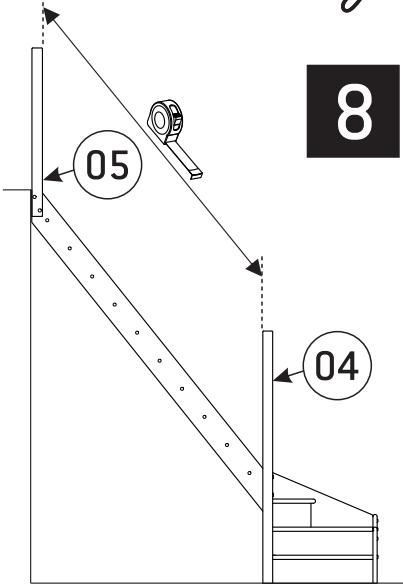

9

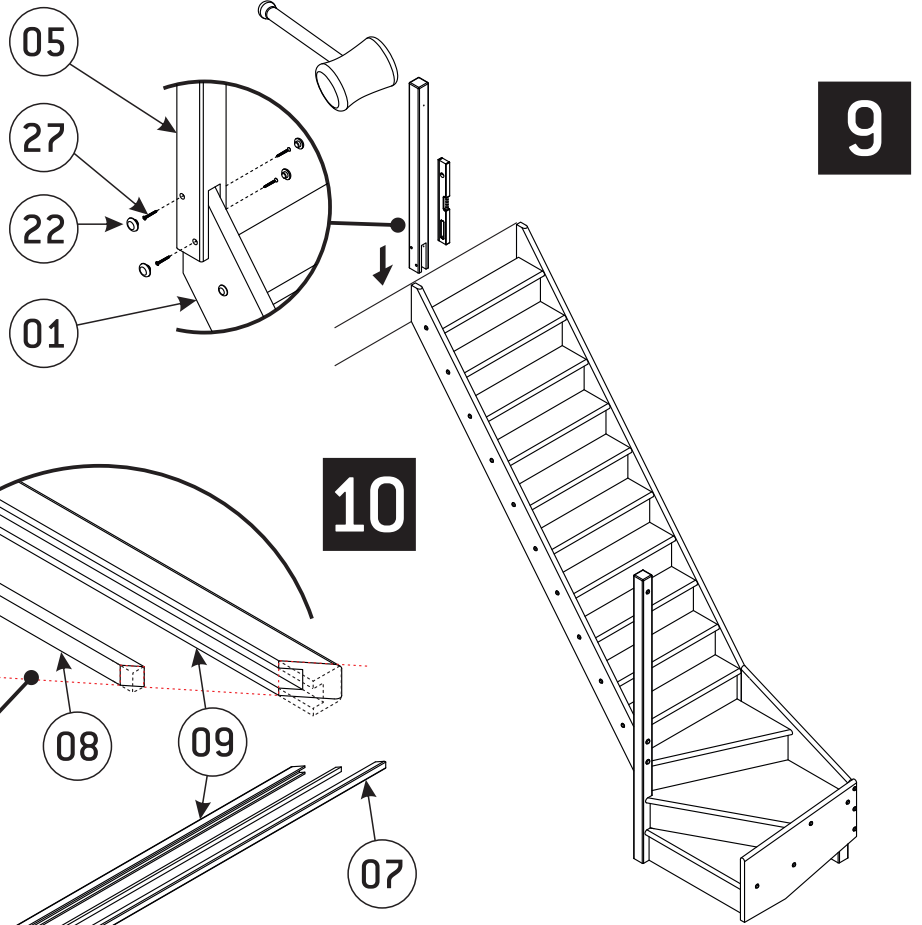

10

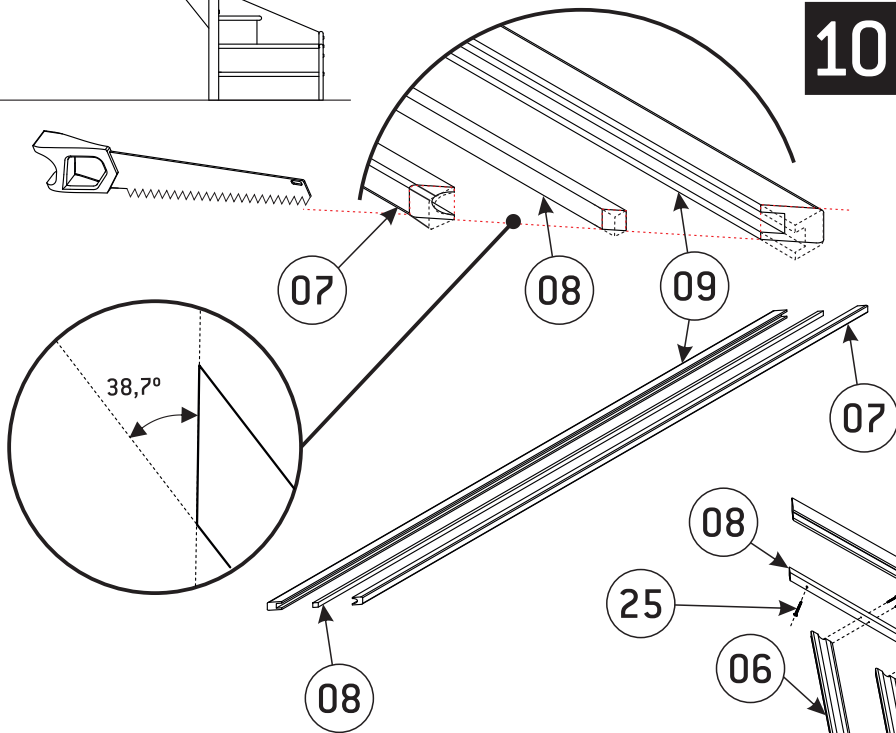

11

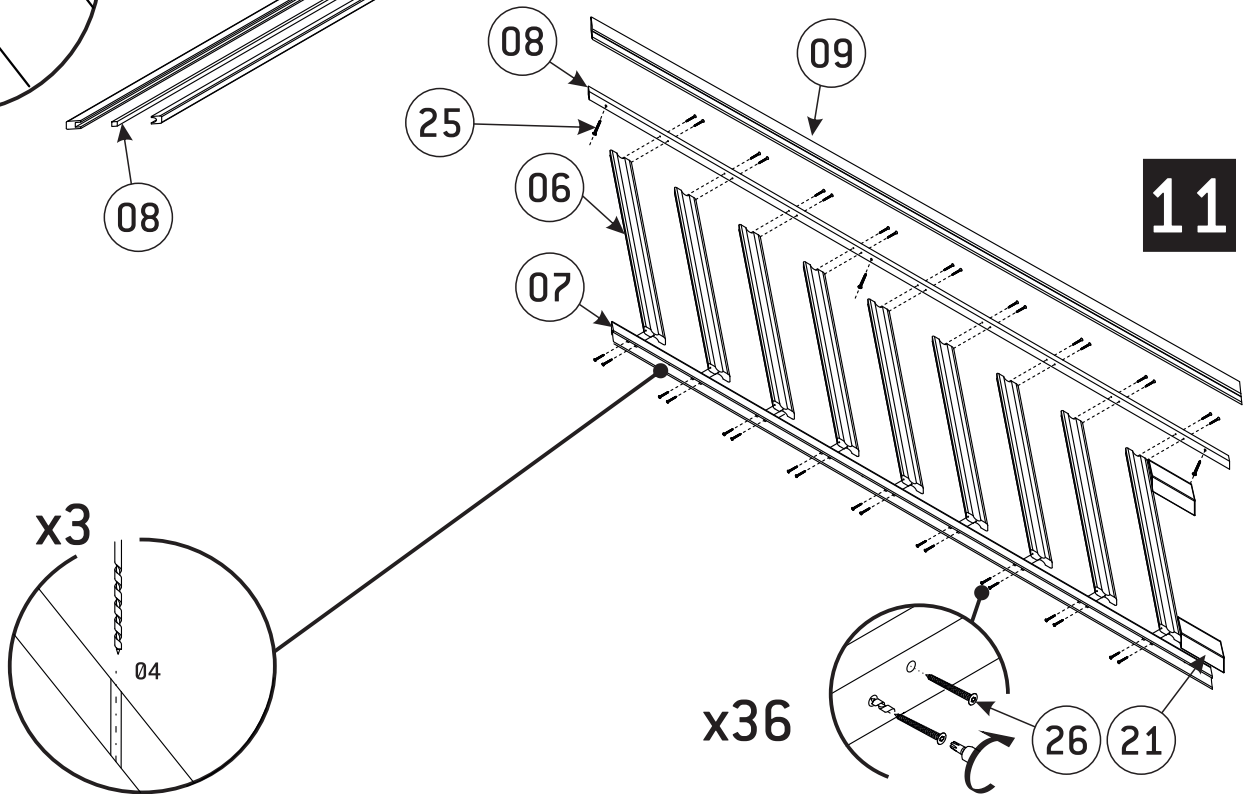

x3

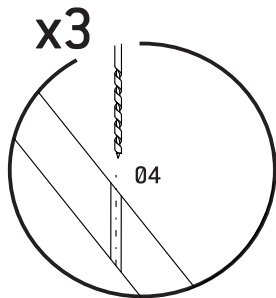

x36

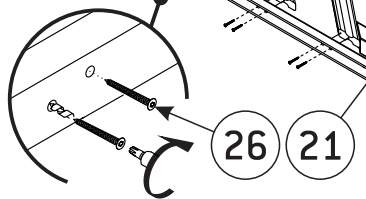



12

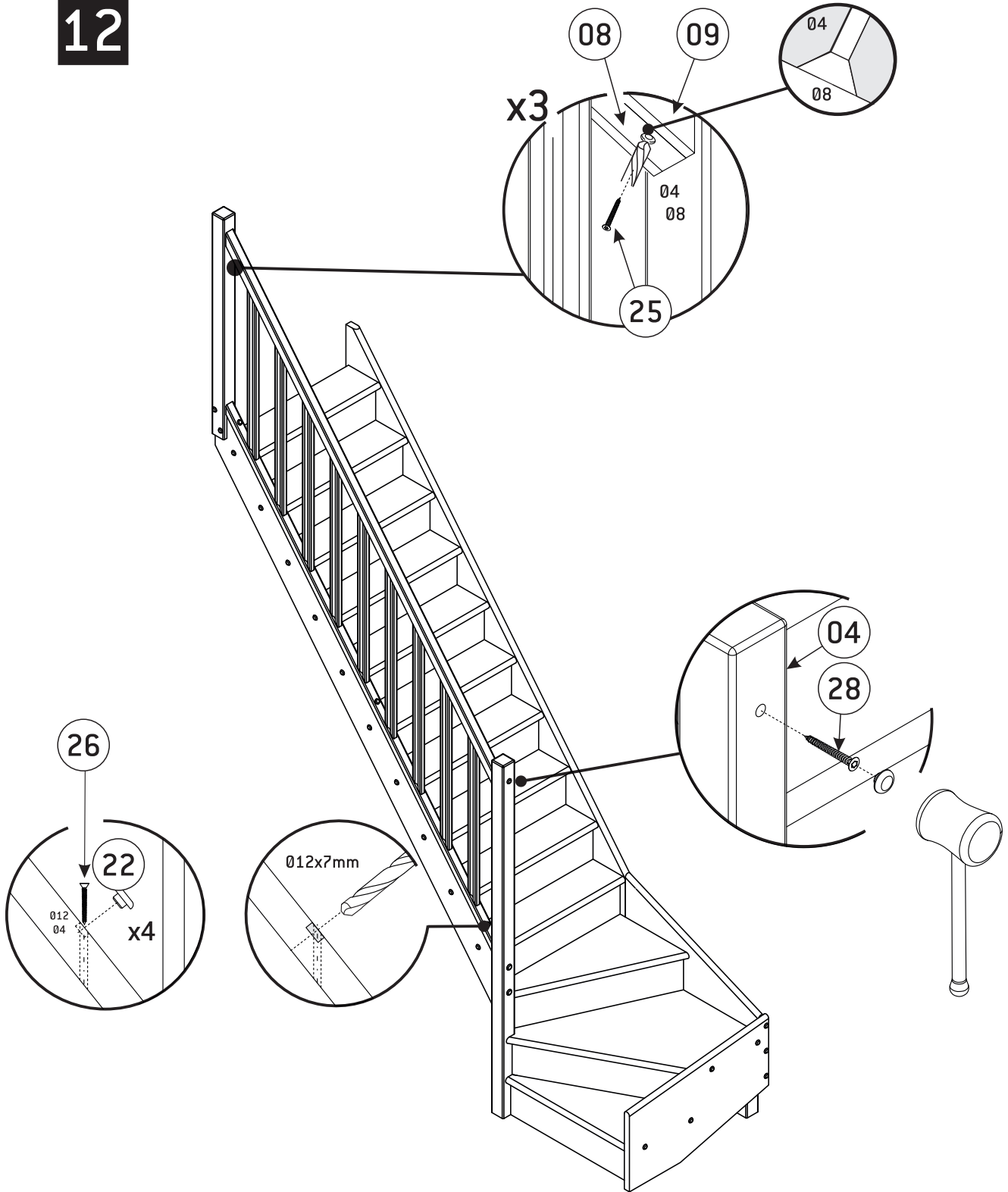

RUE GRIMARD,39 B-6061 MONTIGNIES-SUR-SAMBRE(CHARLEROI)-BELGIUM
TEL: +32/71/25.39.60 FAX: +32/71/25.39.72 E-MAIL: info@sogem-sa.com